

Thor IO8

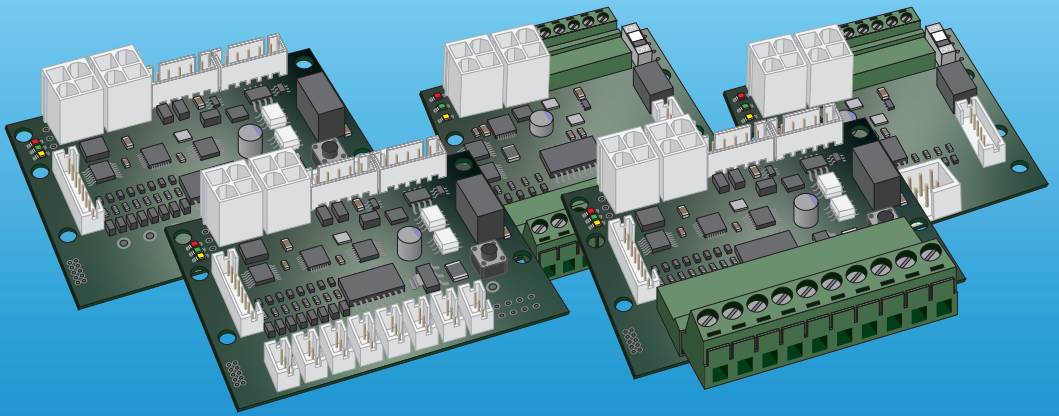

installation manual

Table of content

Technical data	2
Overview main boards	3
IO8	3
IO8 JST	4
IO8 IDC	4
IO8-LC	5
IO8-LC IDC	5
Overview expansion boards	6
IO8 expansion	6
IO8 JST expansion	6
IO8 IDC expansion	6
Expansion boards	7
General information	8
Safety information	8
Incident and issue reporting procedure	9
Incident report flow chart	10
Safely updating the device firmware	11

Technical data

Supply voltage:	18-28 VDC
Max output current for card:	500 mA
Current consumption in standby:	25 mA / 24 V
Size:	H:85 x W:54 x D:20 mm
Size IO8-LC:	H:50 x W:54 x D: 20 mm
Article number:	IO8 screw terminal: 1000005 IO8 JST: 1000004 IO8 IDC: 1000015 IO8-LC screw terminal: 1000016 IO8-LC IDC: 1000017 IO8 expansion screw terminal: 1000018 IO8 expansion JST: 1000019 IO8 expansion IDC: 1000020

IO data:

Supply voltage:	18-28 VDC
Max output current (on each):	200 mA
Input current (on each):	8 mA / 24 VDC

Overview main boards

IO8

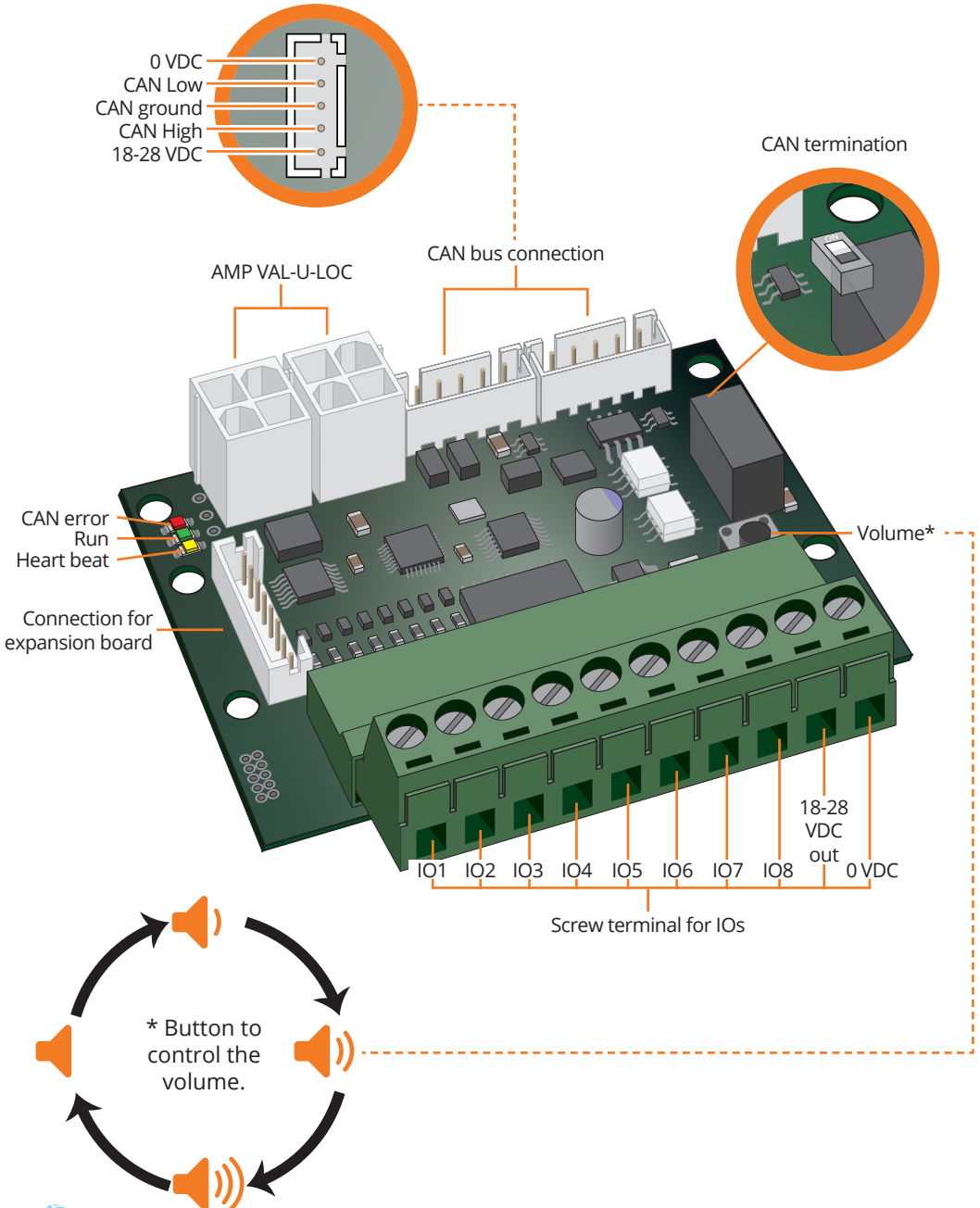

IO8 JST

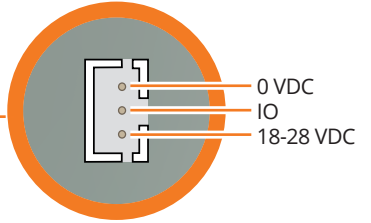
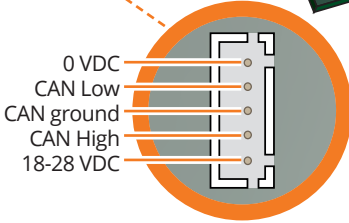
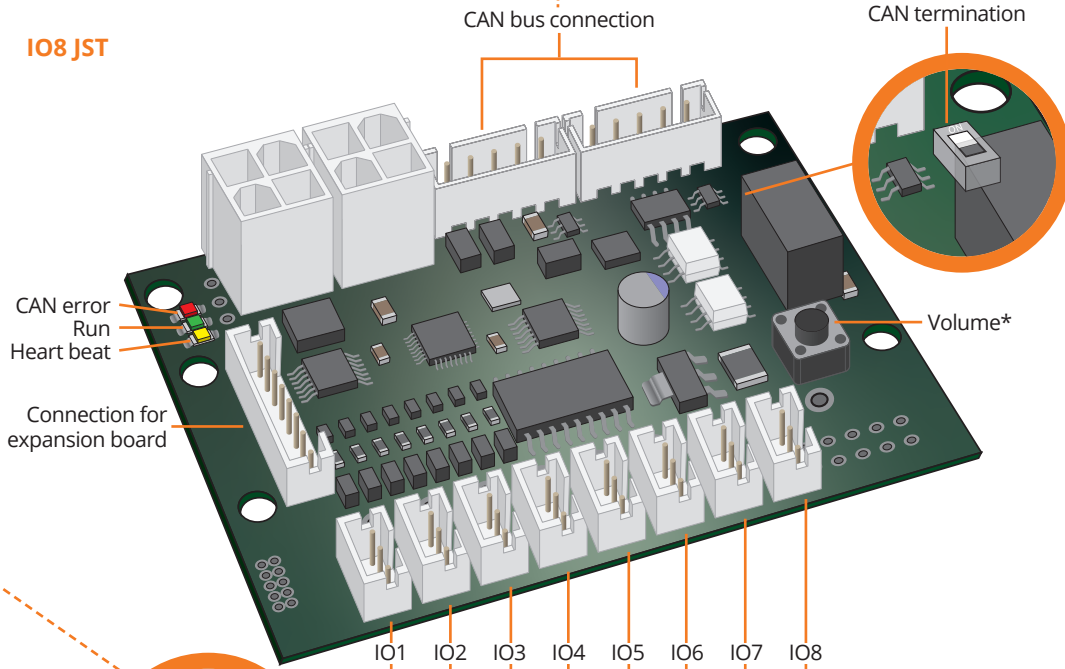

IO8 IDC

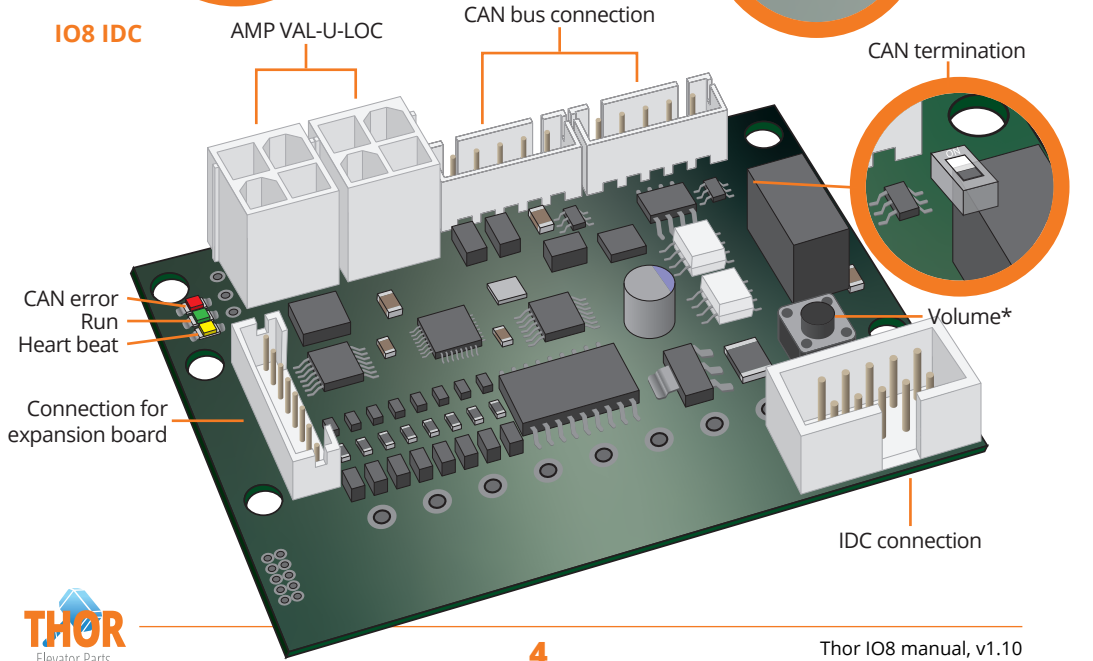

IO8-LC

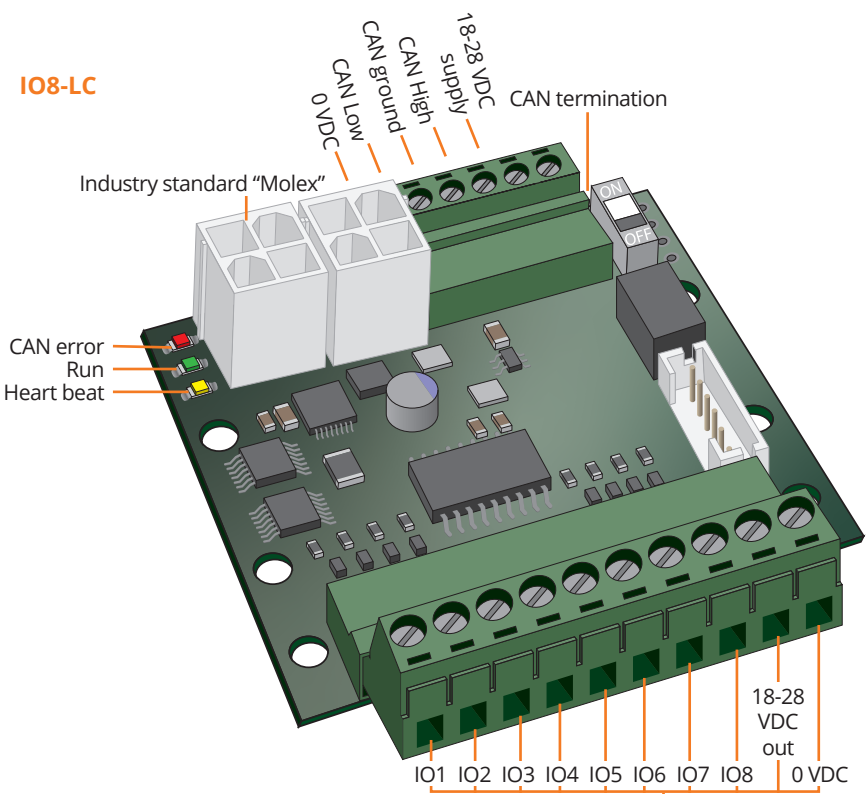

IO8-LC IDC

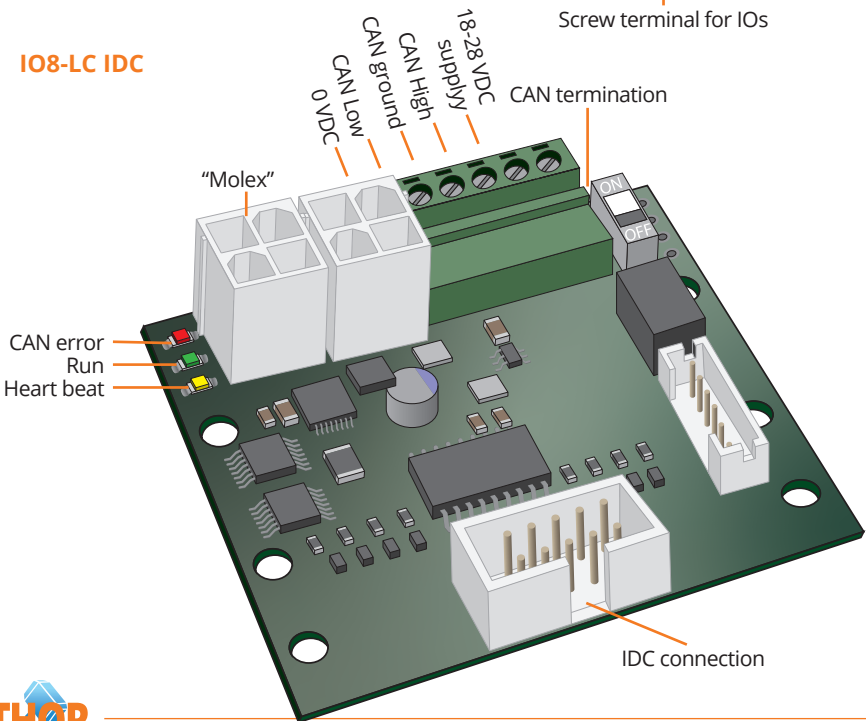

Overview expansion boards

IO8 expansion

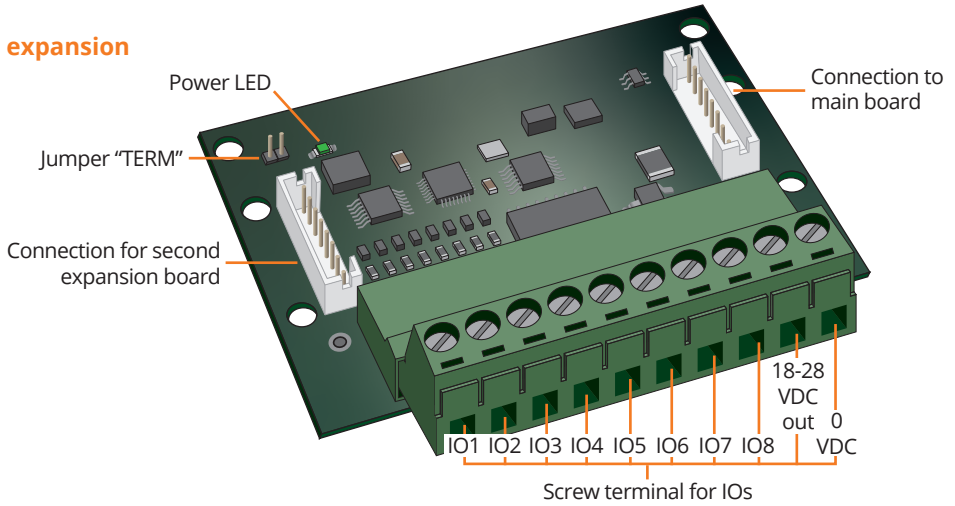

IO8 JST expansion

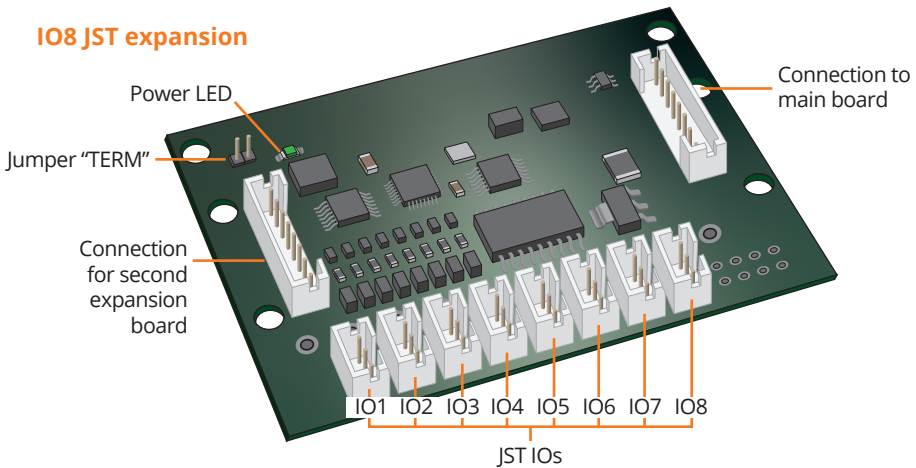

IO8 IDC expansion

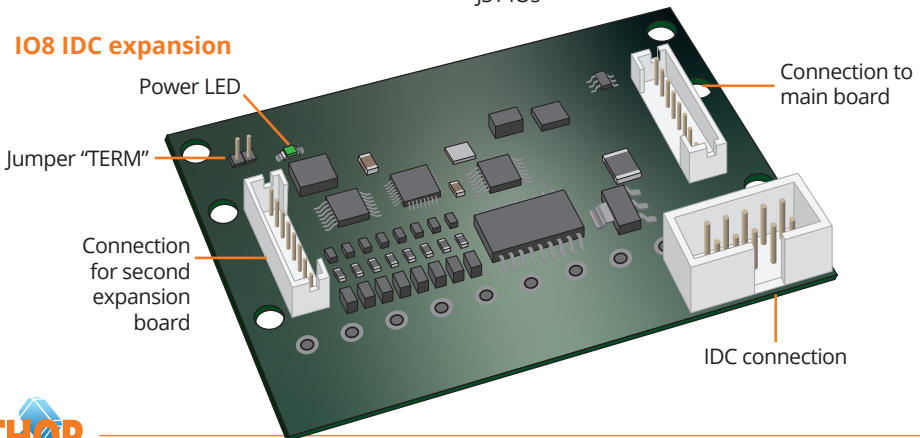

Expansion boards

The IO8 expansion board is a cost effective solution to increase the number of IOs for the Thor IO8 board. Maximum two boards can be connected to one IO8, increasing the total number of IOs to 24. The IO8 expansion board is available with the same connection options as the IO8 main board: screw terminal, JST and IDC.

The jumper "TERM" must be inserted on the last expansion board.

Each expansion board is supplied with a 10 cm cable, it is not recommended to use a longer cable.

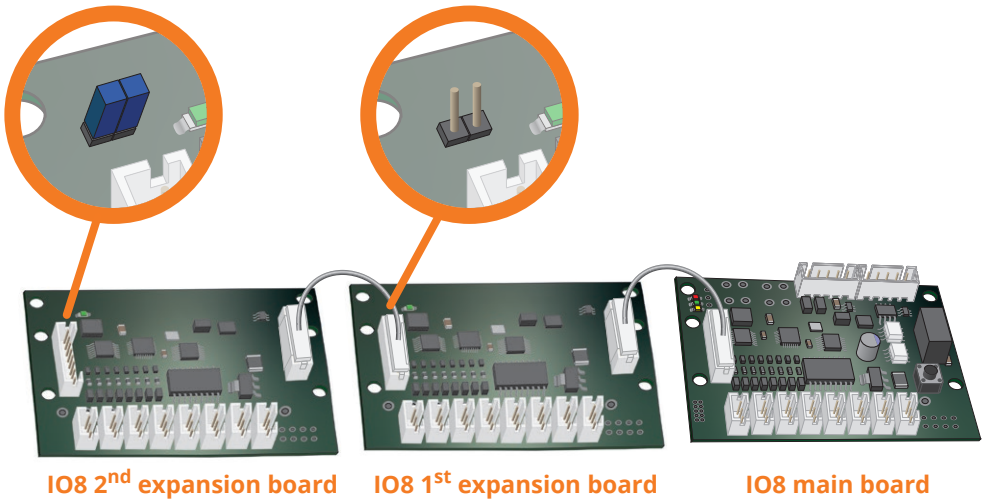

Power to the IO8 main board as well as to all of the IOs **MUST** be disconnected before connecting the expansion board.

General information

Decommissioning

Before disposing of the device, it should be reset to factory settings to ensure that any sensitive or identifiable information is removed. Personal data is generally not stored on the unit, so additional erasure is typically not required. Once reset, the unit must be disposed of properly in accordance with local regulations.

If the device was equipped with a USB device for data backup or voice announcement messages, the USB device must be securely erased (formatted) before disposal. It should then be discarded in compliance with the Electronic Waste Ordinance. For secure data destruction, the DIN 66399 standard (Office and Data Technology – Destruction of Data Carriers) should be followed.

Packaging and disposal

The display is covered with protective foil and other materials to safeguard it during transport.

- » Keep all packaging materials away from children.
- » This device must not be disposed of with household waste.
- » When decommissioning, the display and its components should be taken to a designated electronic waste collection point for proper recycling, in accordance with the Electronic Waste Ordinance.
- » Packaging materials should be recycled at an appropriate recycling center.

Before recycling the unit, consider whether the display or its components can be reused or resold. Selling the unit via classified ads or online marketplaces may be an option. Reuse is always preferable to recycling.

Safety information

Liability

Thor Parts AB or any of its collaboration partners is not liable with respect to the buyer of this product or to any third parties for damage, loss, costs or work incurred as a result of accidents, misuse of the product, incorrect installation or illegal changes, repairs or additions. Claims under warranty are likewise excluded in such cases. Thor Parts AB accepts no liability arising from printing errors, mistakes or changes.

Safety Precautions!

- » Only trained professionals, that are authorised to work on the equipment, should install, configure and use this product.
- » This product is intended for the elevator industry. It has been designed and manufactured to be used for its specified purpose only. It must not be used for any other purpose without the producer's consent.
- » The product cannot be modified or altered in any way and should only be installed and configured strictly following the procedures described in this manual.
- » All applicable health and safety requirements and equipment standards must be considered and strictly adhered to, when installing and configuring this product.
- » After installing and configuring this product, the operation of the equipment should be fully tested to ensure correct operation, before the equipment is returned to normal use.

Incident and issue reporting procedure

In the event of an incident, it is crucial that Thor Parts AB follows a structured procedure for responding. Bug reports, errors, security concerns, issues, and incident reports can be submitted to us via the incident report form on our website.

Submitted reports must be clear, complete, and concise. The form includes several required fields, such as:

- The name of the person submitting the report
- The identification number of the unit/controller
- A valid email address
- Sufficient information to verify and assess the incident

Please ensure that the incident is described in detail, including steps to reproduce the issue if applicable.

The incident report serves as documentation for any event that has caused or could potentially cause a functional or security issue with the product. It captures what has happened and typically includes the steps required to replicate the issue.

The below RACI diagram shows the responsibilities for handling incident reports within the Thor Parts AB organization as of the publishing of this manual.

	Lars Gustafsson	Tommy Nettelstad
R - Responsible C - Consulted I - Informed		
Customer contact (START)	I	R
Gathering details (CREATE)	R	C
Checking/Validating (TO DO)	R	C
Creating test case (IMPLEMENTATION)	R	
Fixing issue (IMPLEMENTATION)	R	
Testing solution (TEST/REVIEW)	R	
Update documentation (REVIEW)	R	C
Notify customer (RELEASE)	I	R

Incident report flow chart

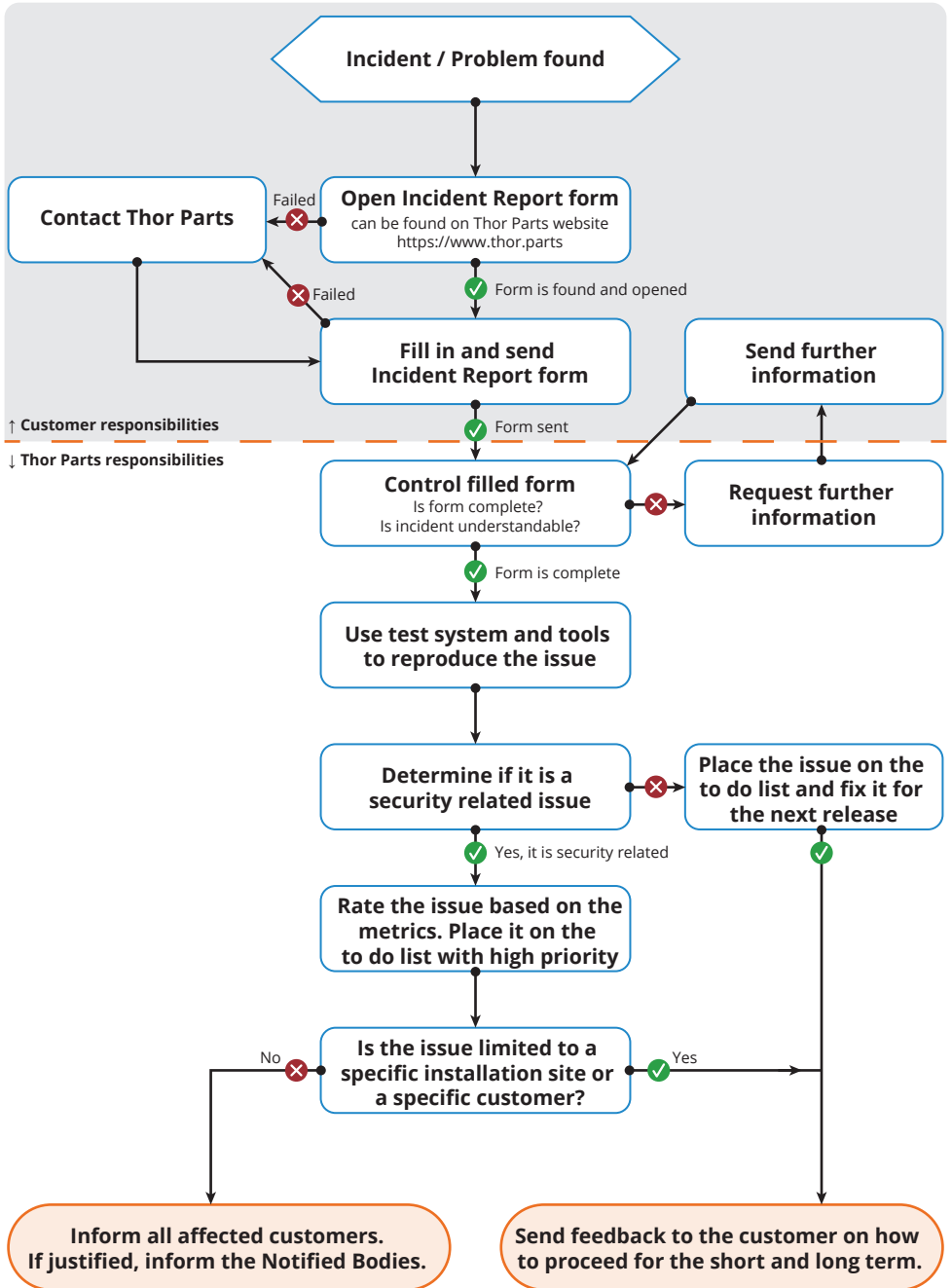

Safely updating the device firmware

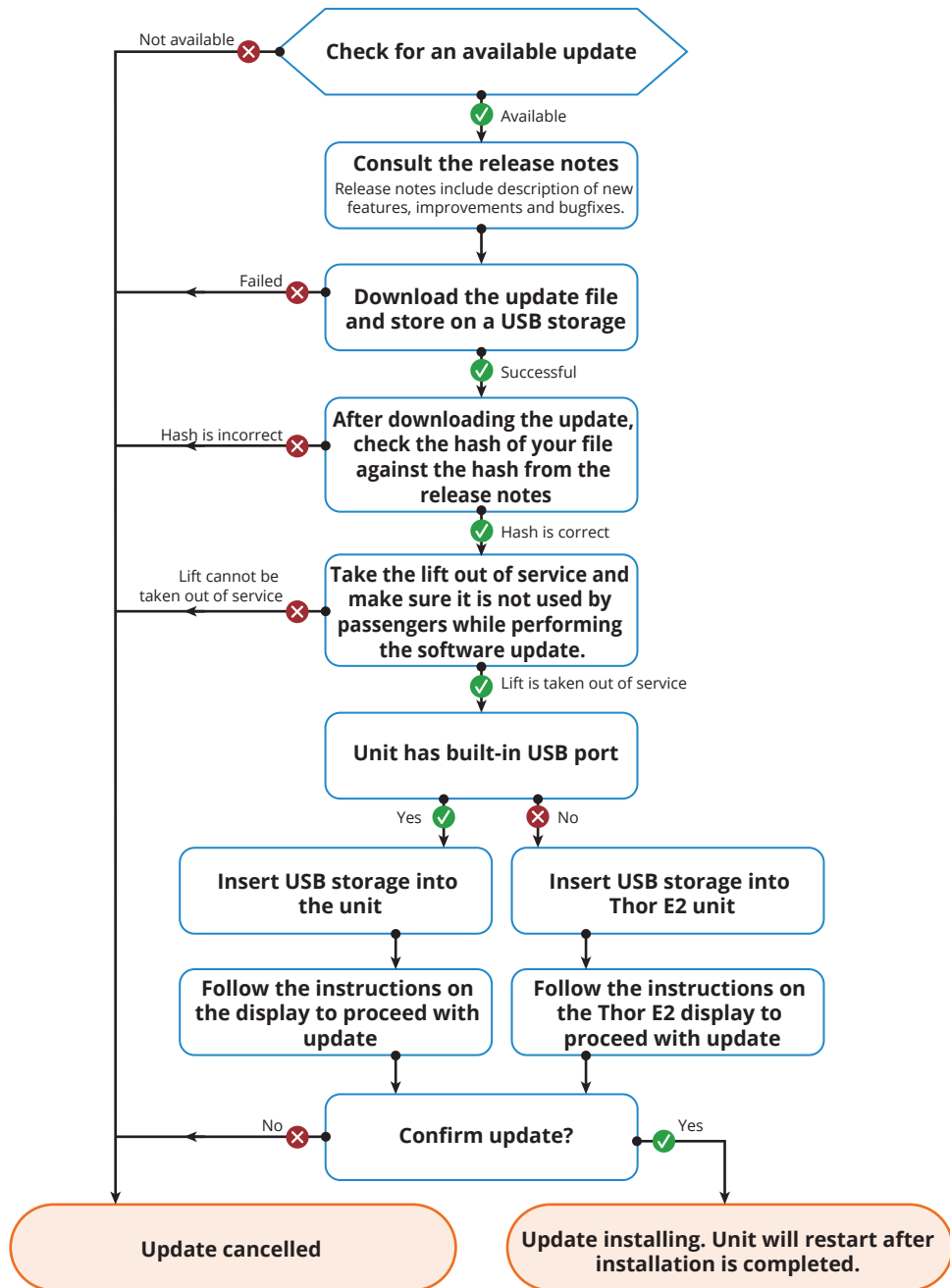

Contact us:

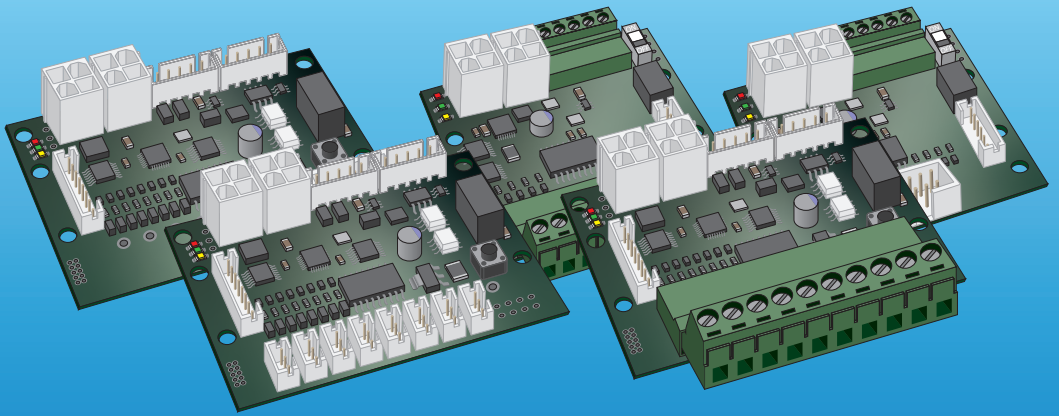

Thor Parts AB
Antennvägen 10
135 48 Tyresö
Sweden

Telephone: +46 (0)8-555 020 40
E-mail: sales@thor.parts

www.thor.parts